

Glycol Feed Systems

Purpose

Neptune Glycol Feeders are designed for the addition of glycol solution to closed loop chilled or hot water systems. The system automatically maintains pressure in the loop by adding glycol solution to make up for losses which occur due to leakage.

Glycol addition is controlled by a pressure switch with adjustable low and high set points.

Standard Pressure Switch:

Cut-In Range: 10-45 PSI Cut-Out Range: 20-60 PSI

Adjustable Differential: 10-30 PSI

Other pressure switches available.

When the pressure in the loop reaches the low set point, the pump begins to feed glycol into the system until the high pressure set point is achieved and stops the pump.

Features

- 50 gallon polyethylene tank mounted in a steel frame
- Bronze rotary gear pump (1.5 gpm @ 100 psi)
- Float switch for low level pump shutoff and alarm
- NEMA 4X control panel

Panel includes:

- Hand-off-auto selector switch for pump motor
- Pump "on" indicator light
- "Low" tank level indicator light
- Dry contact for remote low level indication
- Power cord with plug, 115V 60C

Optional audible alarm and push button silence available.

(Audible alarm is not watertight.)

Neptune
CHEMICAL PUMP CO., INC.



**MODEL
G-50-1**

Each Neptune Glycol Feeder is fully piped and wired with the following components:

Suction assembly includes:

- PVC tubing and fittings
- PVC ball valve
- Cast iron "Y" strainer

Discharge assembly includes:

- Schedule 40 brass pipe and fittings
- PVC ball valve • Brass check valve • Pressure gauge
- Brass relief valve with return to tank tubing

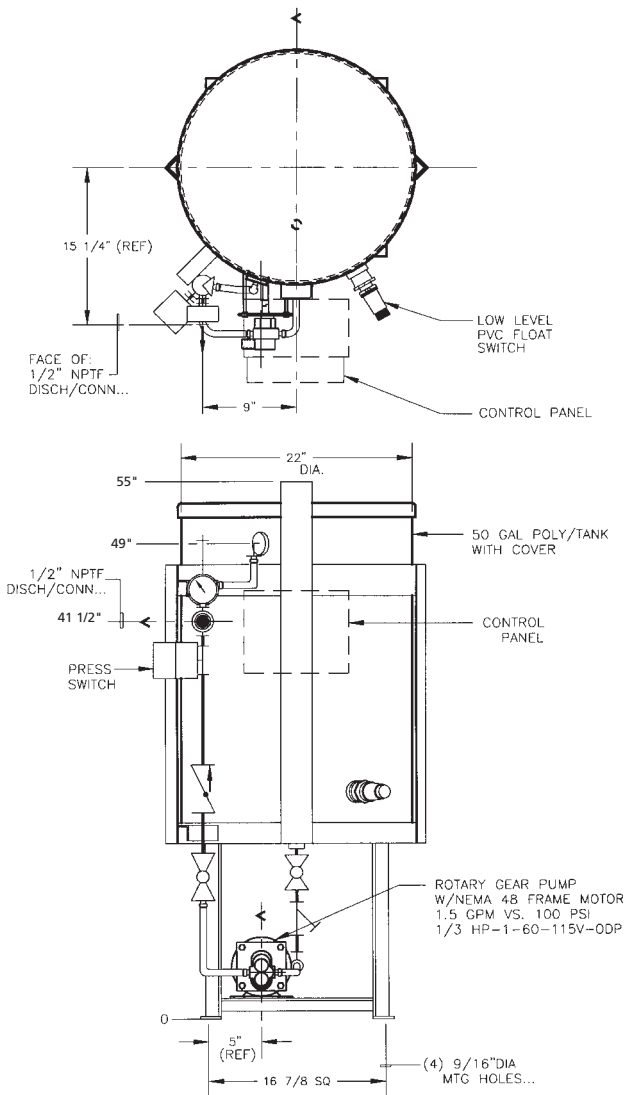

MODEL G-50-1 & G-50-1A

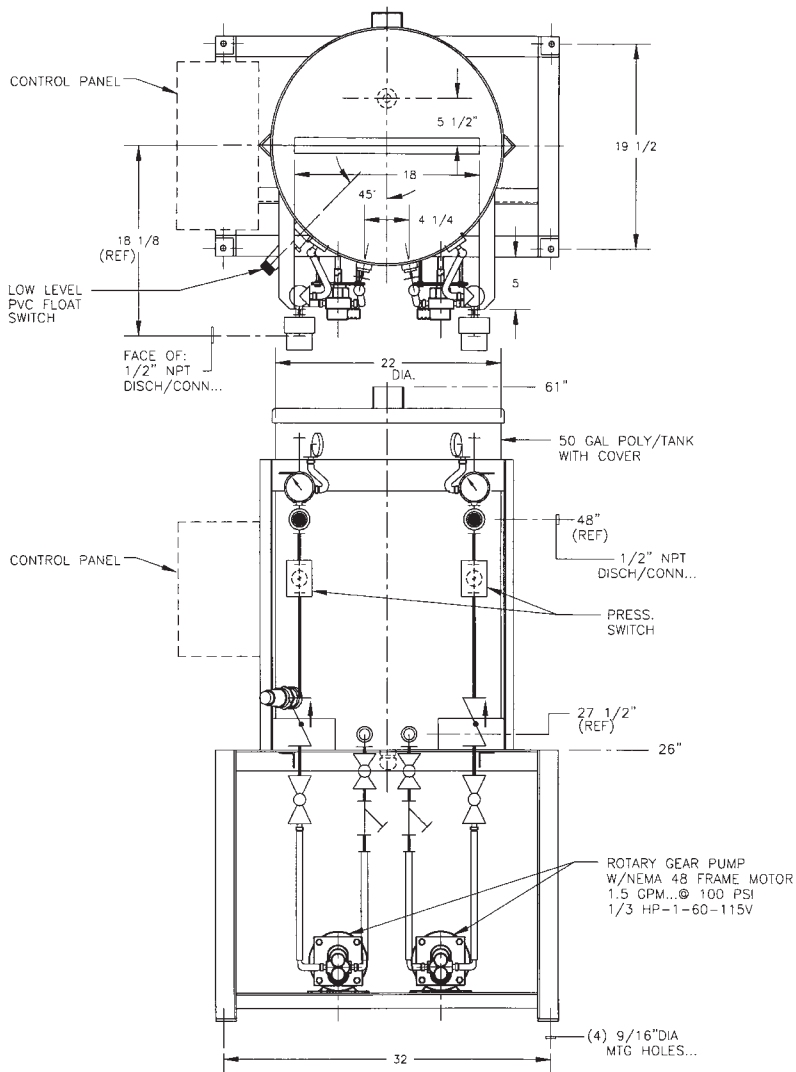

MODEL G-50-2A

SELECTION CHART

MODEL	DESCRIPTION
G-50-1	Complete system including 1.5 gpm (@ 100 psi) pump and low level light.
G-50-1A	Complete system including 1.5 gpm (@ 100 psi) pump, low level light and audible alarm.
G-50-2A	Complete system including two 1.5 gpm (@ 100 psi) pumps, low level light and audible alarm. Separate discharges and pressure switches allow feeding two separate closed loop systems independently from a single tank.
LP	Option to furnish larger pump rated 3.75 gpm (@ 100 psi). Add "LP" to Model Number to specify larger pump; Example G-50-1-LP.

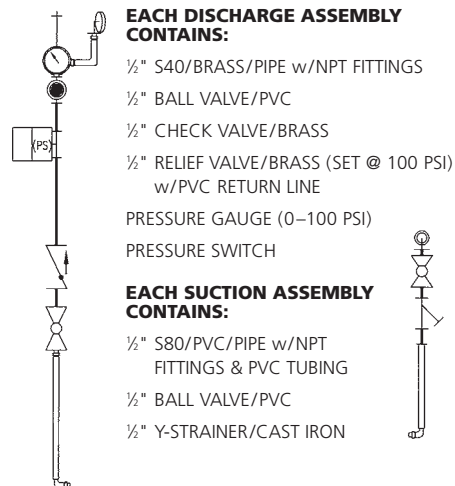

Neptune
CHEMICAL PUMP CO., INC.

SOLD BY:

P.O. Box 247 • Lansdale, PA 19446-0247
Tel: 215-699-8700 • Fax: 215-699-0370
Toll-Free Tel: 1-888-3NEPTUNE (1-888-363-7886)
Toll-Free Fax: 1-800-255-4017
Web Site: <http://www.neptune1.com>
E-mail: pump@neptune1.com